

REVISIONS			
REV.	DESCRIPTION	DATE	APPROVED
A	2018 ISSUE	24/12/2017	

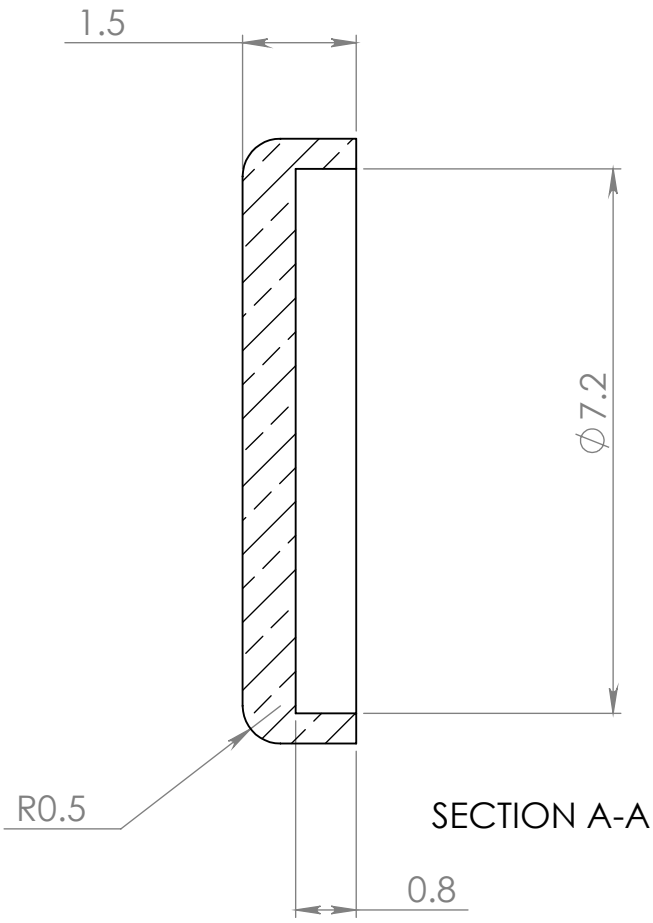
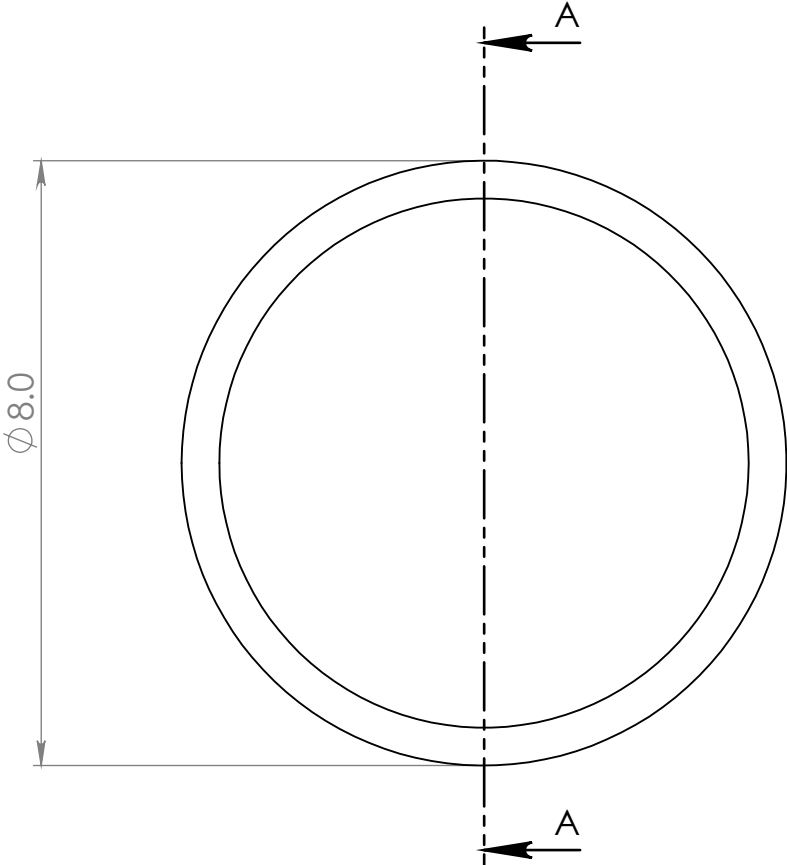

NOTE  
TOTAL QUANTITY REQUIRED = 7/SET

© Machine Concept Ltd  
6 Fieldview, Bar Hill  
Cambridge, CB23 8SX.  
United Kingdom  
Tel: +44 (0) 1954 780772  
mike@machineconcepts.co.uk

All dimensions are in mm  
unless otherwise stated.  
No dec pl : ± 0.5mm  
1 dec pl : ± 0.2mm  
2 dec pl : ± 0.1mm  
3 dec pl : ± 0.05mm  
angular : ± 0.2°  
**DO NOT SCALE**



Drg By. Mike Nelson	Chk'd By. MRN	Approved - date	Model Name SP-DP-043	Date. 13/07/2011	Scale 10:1
Material. BRASS		Title. <b>key pad</b>			
Finish. CLEAN AND SMOOTH		Drg No. <b>SP-DP-043</b>	Sheet number. A4 1 of 1		