

REVISIONS			
REV.	DESCRIPTION	DATE	APPROVED
A	2018 RE-ISSUE	27/12/2017	

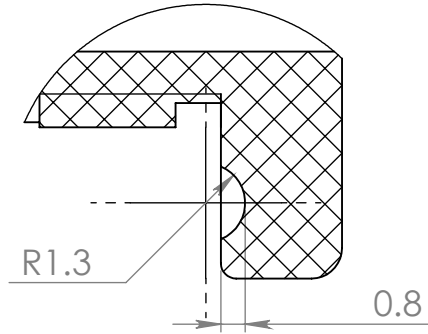

DETAIL B  
SCALE 4 : 1

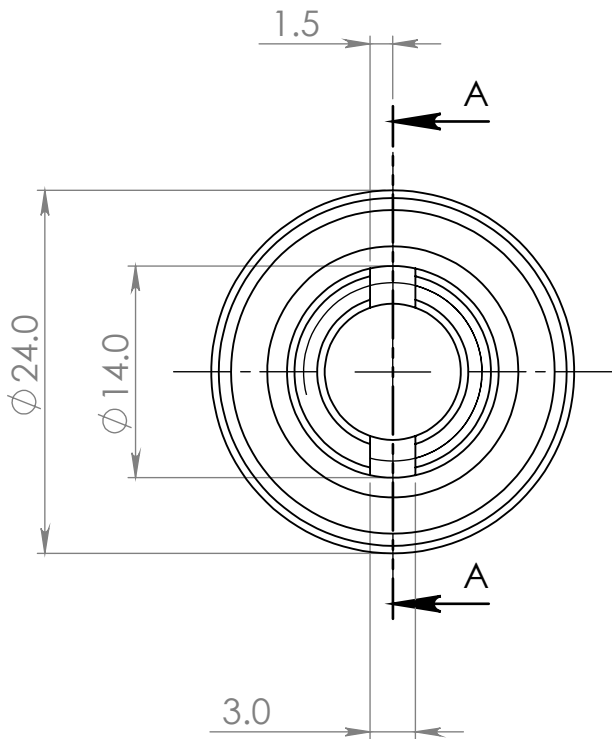
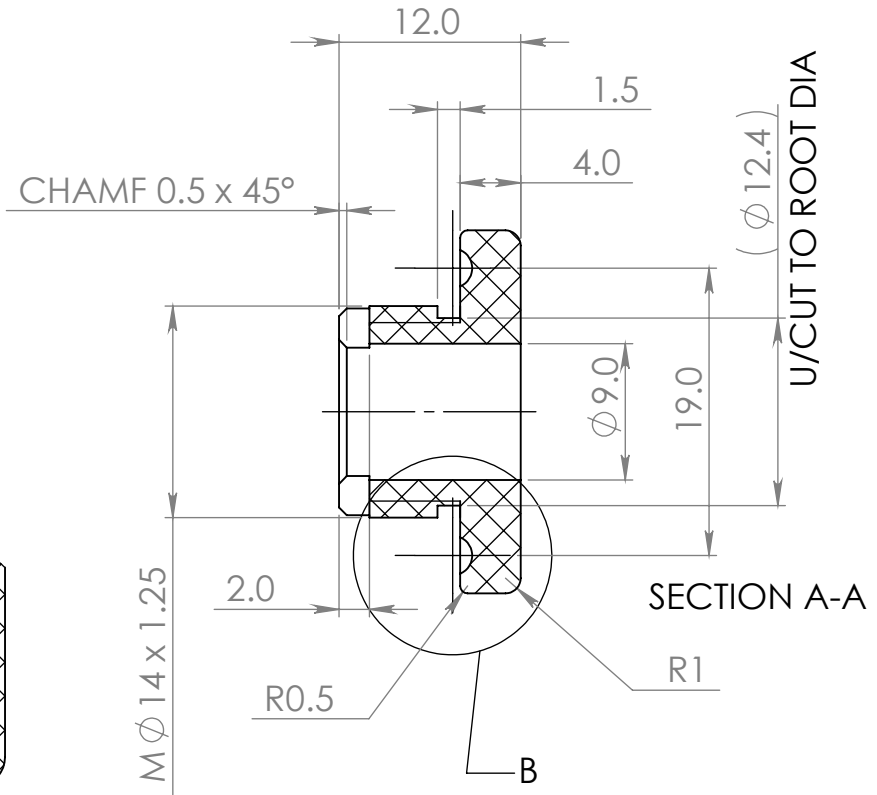

SECTION A-A

© Machine Concept Ltd  
 6 Fieldview, Bar Hill  
 Cambridge, CB23 8SX.  
 United Kingdom  
 Tel: +44 (0) 1954 780772  
 mike@machineconcepts.co.uk

All dimensions are in mm  
 unless otherwise stated.  
 No dec pl : ± 0.5mm  
 1 dec pl : ± 0.2mm  
 2 dec pl : ± 0.1mm  
 3 dec pl : ± 0.05mm  
 angular : ± 0.2°  
**DO NOT SCALE**



Drg By. Mike Nelson	Chk'd By. MRN	Approved - date	Model Name SP-DP-032	Date. 14/09/2011	Scale 2:1
Material. BLACK ACETAL		Title. <b>BLOWPIPE STOCK CLAMP RING</b>			
Finish. CLEAN AND SMOOTH		Drg No. <b>SP-DP-032</b>	Sheet number. A4 1 of 1		