

REVISIONS			
REV.	DESCRIPTION	DATE	APPROVED
A	2018 RE-ISSUE	22/12/2017	

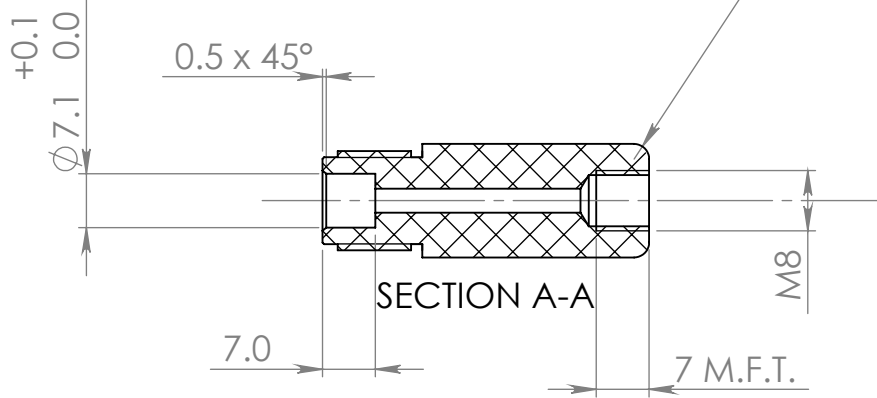
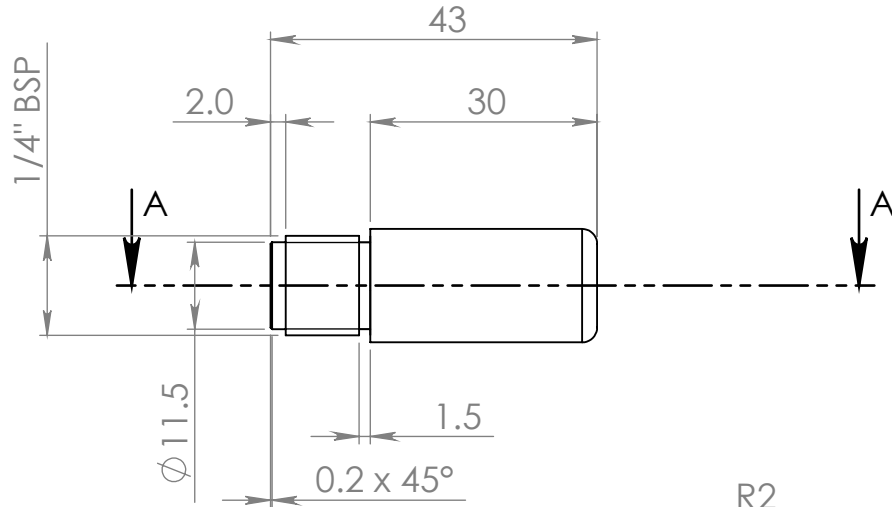
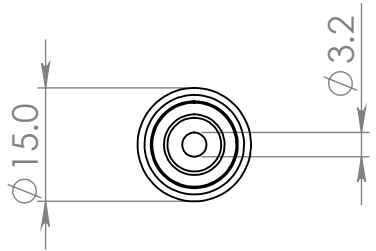

REMOVE ALL BURRS AND SHARP EDGES

© Machine Concept Ltd

6 Fieldview, Bar Hill  
Cambridge, CB23 8SX.  
United Kingdom  
Tel: +44 (0) 1954 780772  
mike@machineconcepts.co.uk

All dimensions are in mm  
unless otherwise stated.  
No dec pl :  $\pm 0.5$ mm  
1 dec pl :  $\pm 0.2$ mm  
2 dec pl :  $\pm 0.1$ mm  
3 dec pl :  $\pm 0.05$ mm  
angular :  $\pm 0.2^\circ$   
**DO NOT SCALE**



Drg By. Mike Nelson	Chk'd By. MRN	Approved - date	Model Name SP-DP-020	Date. 14/09/2011	Scale 1:1
Material. BLACK ACETAL			Title. <b>SMALL G DRONE STANDING PART BASE</b>		
Finish. CLEAN AND SMOOTH			Drg No. <b>SP-DP-020</b>	Sheet number. A4 1 of 1	