

REVISIONS			
REV.	DESCRIPTION	DATE	APPROVED
A	2018 RE-ISSUE	22/12/2017	

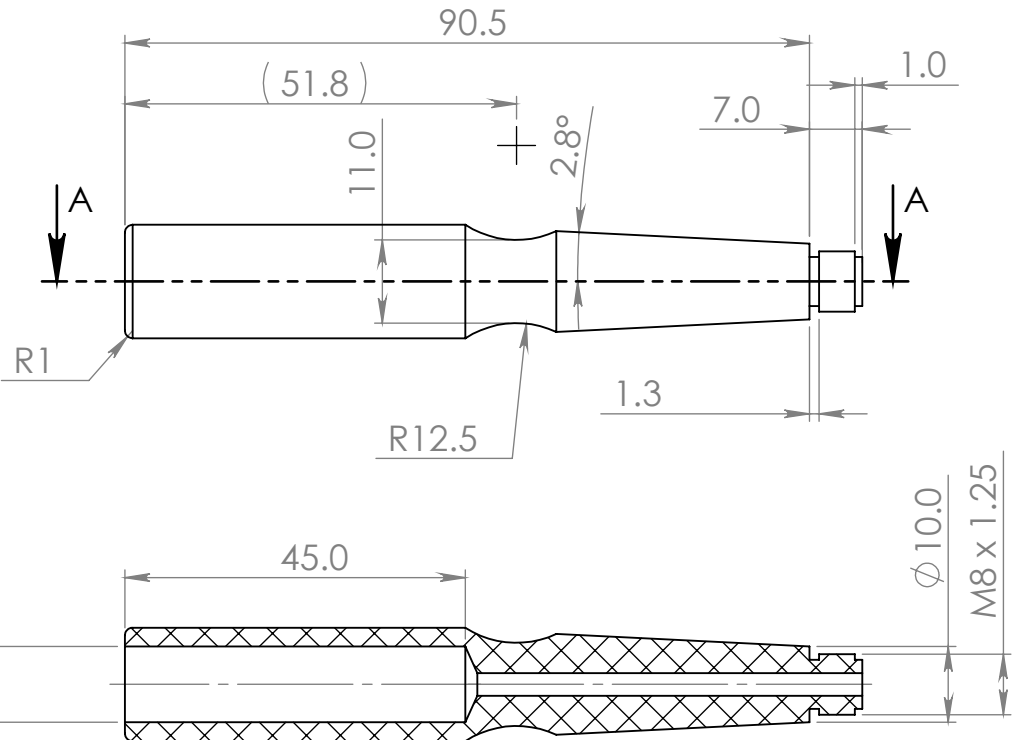

Ø 10.0 SEE NOTE 1

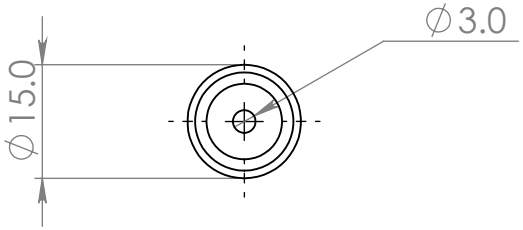
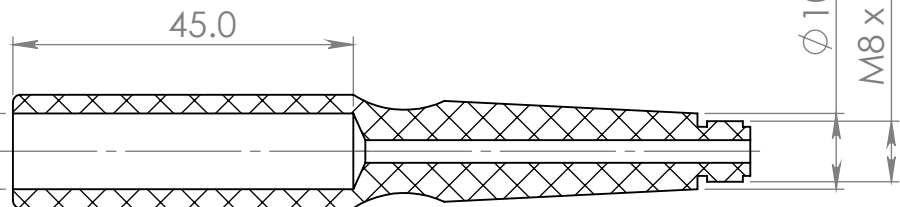

SECTION A-A

NOTES
 1. THIS BORE MUST BE A FIRMPRESS FIT5 ON THE BRASS LINING TUBE ITEM No SP-DP-013

REMOVE ALL BURRS AND SHARP EDGES

© Machine Concept Ltd
 6 Fieldview, Bar Hill
 Cambridge, CB23 8SX.
 United Kingdom
 Tel: +44 (0) 1954 780772
 mike@machineconcepts.co.uk

All dimensions are in mm unless otherwise stated.
 No dec pl : ± 0.5mm
 1 dec pl : ± 0.2mm
 2 dec pl : ± 0.1mm
 3 dec pl : ± 0.05mm
 angular : ± 0.2°
DO NOT SCALE



Drg By. MRN	Chk'd By.	Approved - date	Model Name SP-DP-019	Date. 13/09/2011	Scale 1:1
Material. BLACK ACETAL		Title. SMALL D SLIDING PART BODY			
Finish. CLEAN AND SMOOTH		Drg No. SP-DP-019	Sheet number. A4 1 of 1		