

REVISIONS			
REV.	DESCRIPTION	DATE	APPROVED
A	2018 RE-ISSUE	22/12/2017	

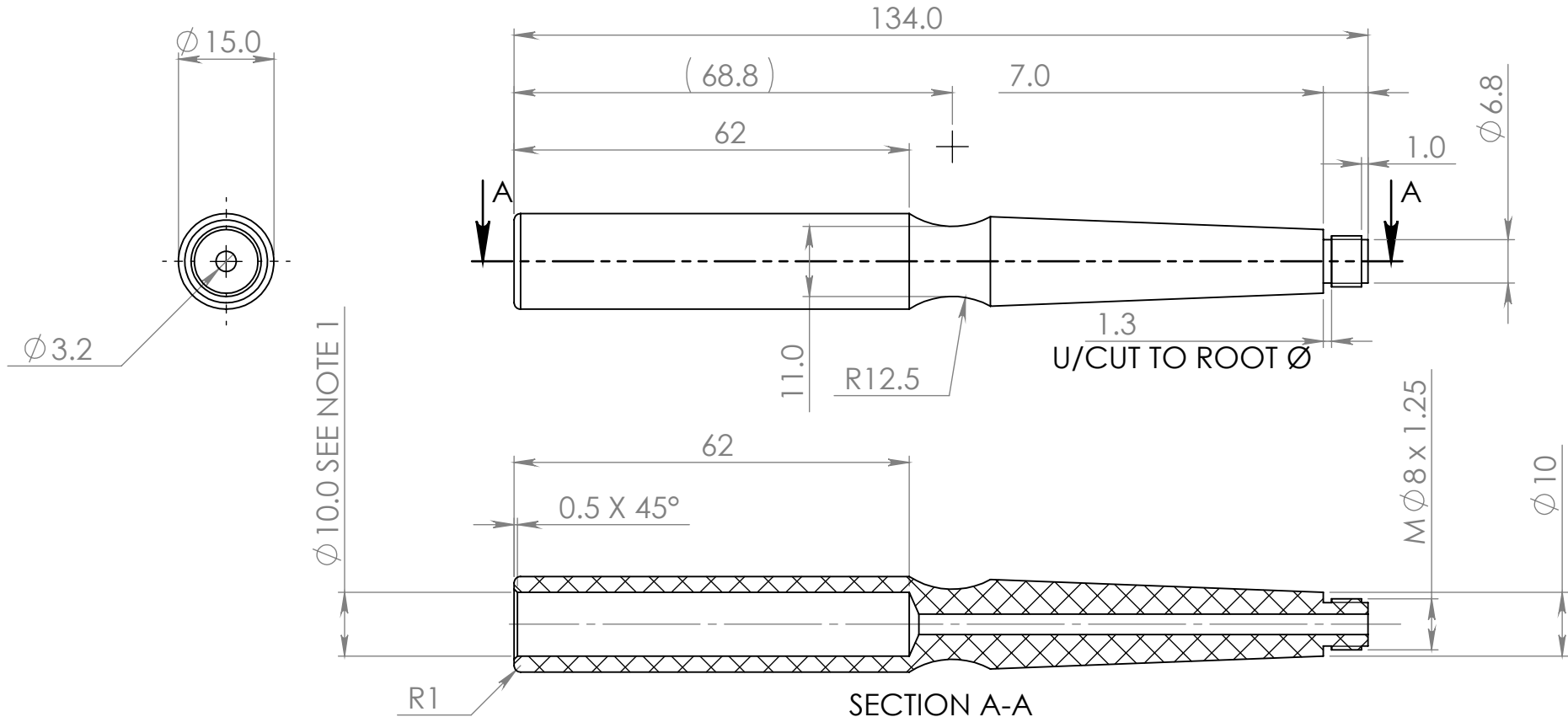

NOTES

- THIS BORE MUST BE A FIRMPRESS FIT5 ON THE BRASS LINING TUBE ITEM No SP-DP-013

REMOVE ALL BURRS AND SHARP EDGES

<p>© Machine Concept Ltd 6 Fieldview, Bar Hill Cambridge, CB23 8SX. United Kingdom Tel: +44 (0) 1954 780772 mike@machineconcepts.co.uk</p>	<p>All dimensions are in mm unless otherwise stated. No dec pl : ± 0.5mm 1 dec pl : ± 0.2mm 2 dec pl : ± 0.1mm 3 dec pl : ± 0.05mm angular : ± 0.2° DO NOT SCALE</p>	Drg By. Mike Nelson	Chk'd By. MRN	Approved - date	Model Name SP-DP-017	Date. 13/09/2011	Scale 1:1	
		Material. BLACK ACETAL		Title. LARGE G DRONE SLIDING PART				
		Finish. CLEAN AND SMOOTH		Drg No. SP-DP-017			Sheet number. A4 1 of 1	
		<p>3rd Angle</p>						