

REVISIONS			
REV.	DESCRIPTION	DATE	APPROVED
B	SEE NOTE	20/09/2011	

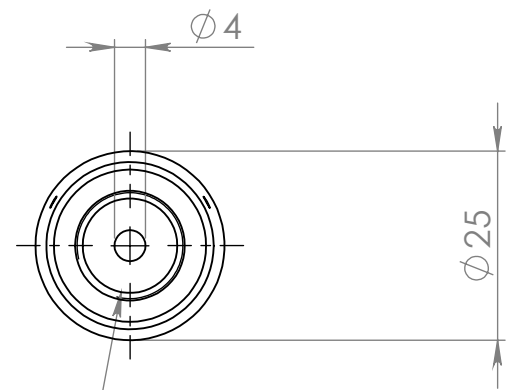
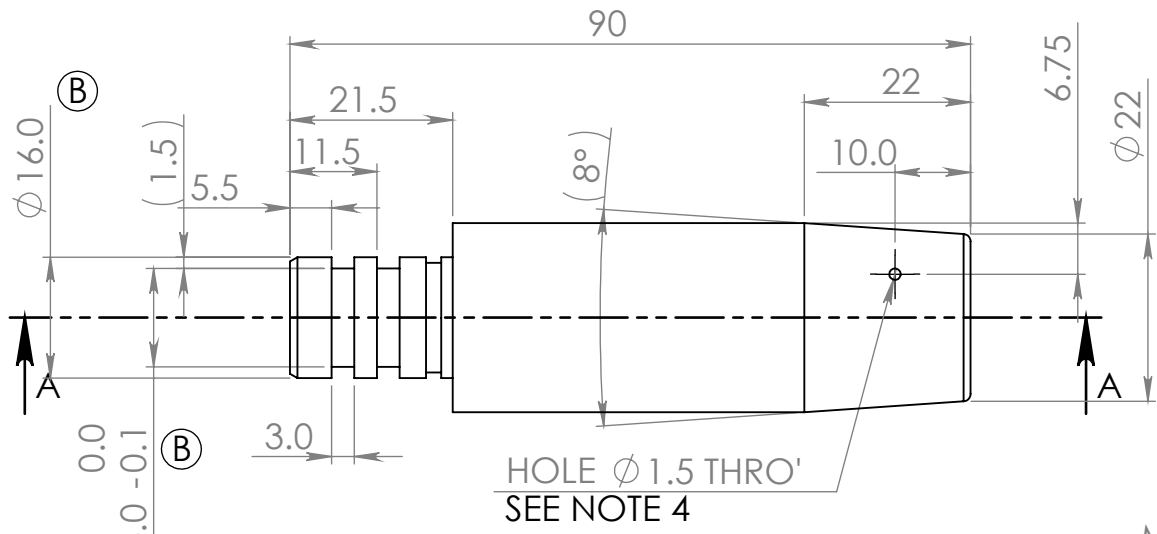

$\phi \text{ } \varnothing 12.75 \nabla 23.5$
 $M14 \times 1.25 - 6H \nabla 16.0$

HOLE $\phi 1.5$ THRO'
 SEE NOTE 4

- NOTE**
1. DIMENSION NOW $\varnothing 16.0$ SHOULD BE $\varnothing 16.9$ IF NEW PARTS ARE MADE
 2. ORING GROOVE NOW 3mm WIDE WAS 1.68mm
 3. THIS DESIGN IS MODIFIED FROM AS SUPPLIED PARTS TO CURE THE PROBLEM OF THE ORING PUSHING OUT OF THE GROOVE WHEN THE STOCK IS INSERTED INTO THE BAG.
 4. THIS HOLE IS FOR A PIN TO LOCK THE CHANTER IN THE STOCK BUT MAY NOT BE NEEDED.

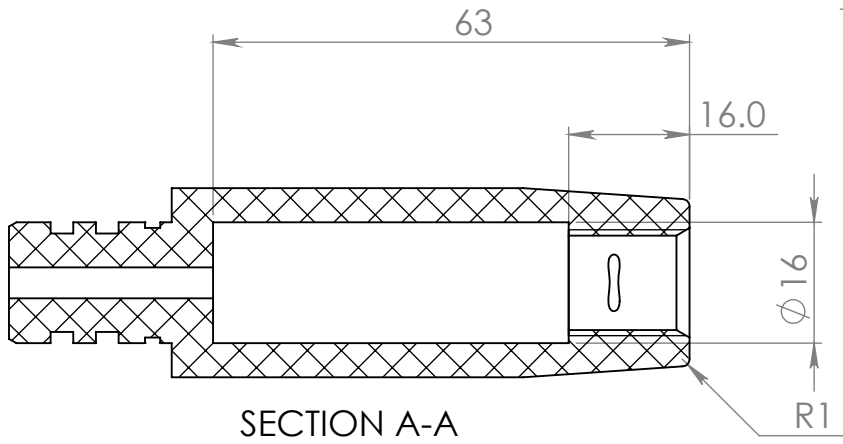

SECTION A-A

© Machine Concept Ltd
 6 Fieldview, Bar Hill
 Cambridge, CB23 8SX.
 United Kingdom
 Tel: +44 (0) 1954 780772
 mike@machineconcepts.co.uk

All dimensions are in mm
 unless otherwise stated.
 No dec pl : $\pm 0.5\text{mm}$
 1 dec pl : $\pm 0.2\text{mm}$
 2 dec pl : $\pm 0.1\text{mm}$
 3 dec pl : $\pm 0.05\text{mm}$
 angular : $\pm 0.2^\circ$
DO NOT SCALE



Drg By. MRN	Chk'd By.	Approved - date	Model Name SP-DP-005	Date. 20/09/2011	Scale 1:1
Material. BLACK ACETAL	Title. AS USED CHANTER STOCK				
Finish. CLEAN AND SMOOTH	Drg No. SP-DP-005	Sheet number. A4 1 of 1			