

| REVISIONS | | | |
|-----------|--------------|------------|----------|
| REV. | DESCRIPTION | DATE | APPROVED |
| A | 2018 REISSUE | 22/12/2017 | |

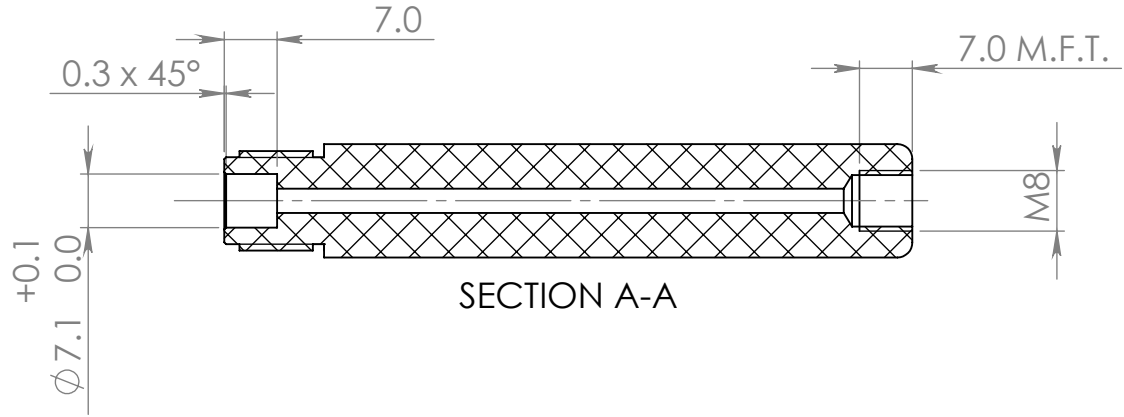

© Machine Concept Ltd
 6 Fieldview, Bar Hill
 Cambridge, CB23 8SX.
 United Kingdom
 Tel: +44 (0) 1954 780772
 mike@machineconcepts.co.uk

All dimensions are in mm
 unless otherwise stated.
 No dec pl : ± 0.5mm
 1 dec pl : ± 0.2mm
 2 dec pl : ± 0.1mm
 3 dec pl : ± 0.05mm
 angular : ± 0.2°
DO NOT SCALE

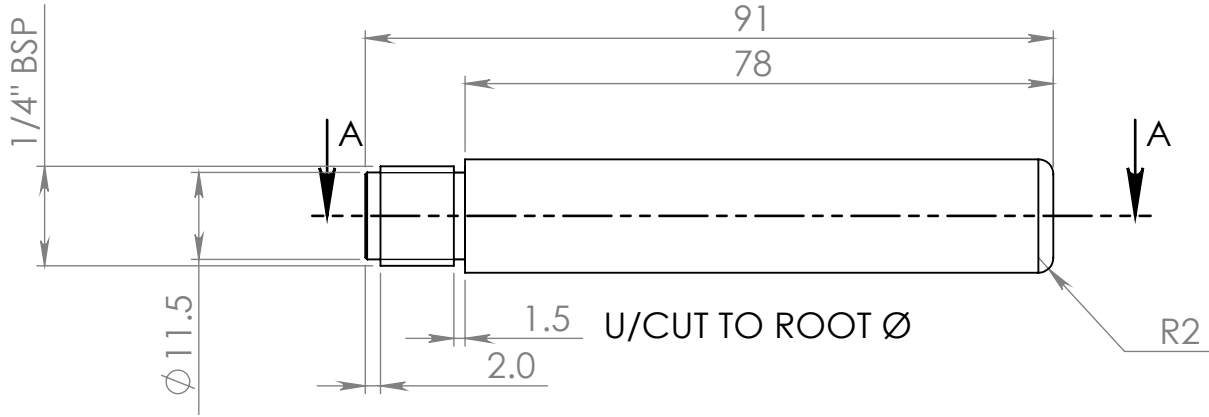
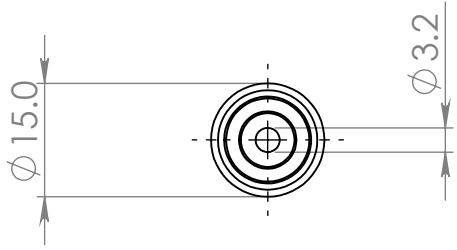

| | | | | | |
|-----------------------------|------------------|-----------------|---------------------------------------------|----------------------------|--------------|
| Drg By. Mike Nelson | Chk'd By. MRN | Approved - date | Model Name SP-DP-002 | Date. 14/09/2011 | Scale 1:1 |
| Material. BLACK ACETAL | | | Title. G DRONE STANDING PART BASE | | |
| Finish. CLEAN AND SMOOTH | | | Drg No. SP-DP-002 | Sheet number. A4 1 of 1 | |