

SECTION A-A
PROP DRIVER AL ALLOY

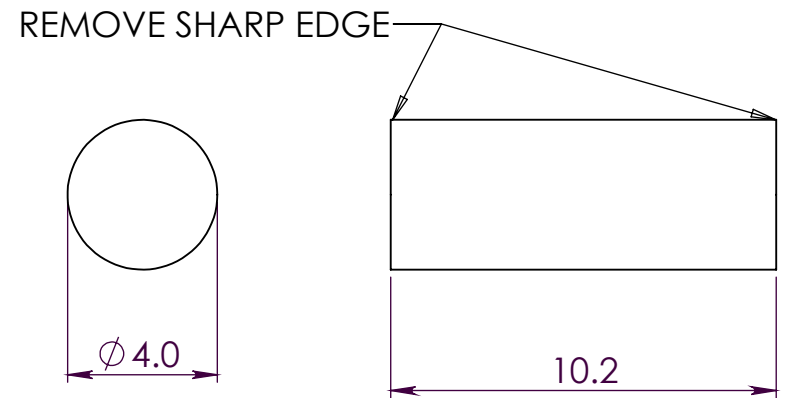

REMOVE SHARP EDGE
MAKE FROM ROLLER BEARING ROLLER
CRANK PIN

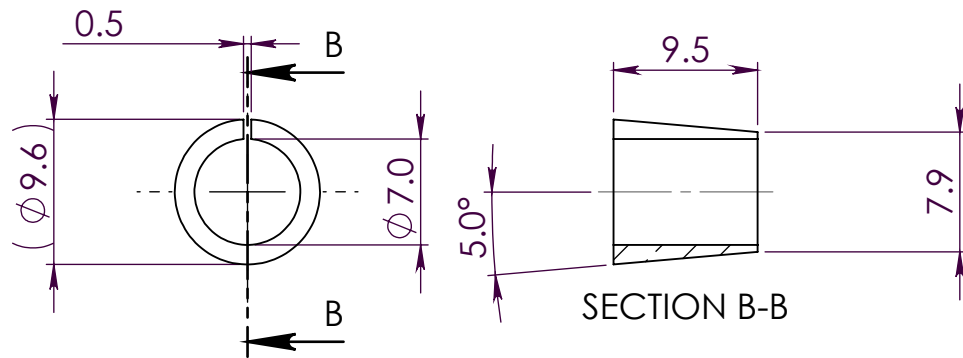

SECTION B-B
PROP DRIVER COLLET BRASS

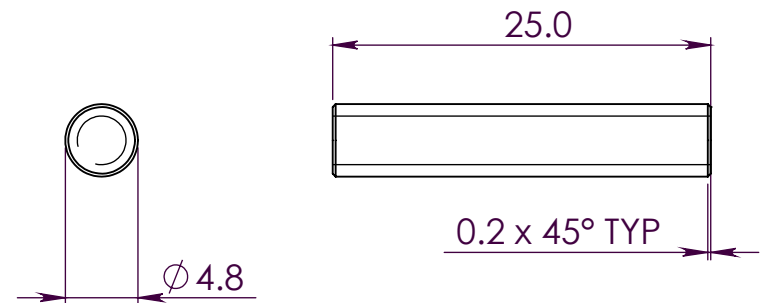

PROP STUD MILD STEEL

© Machine Concept Ltd

All dimensions are in mm unless otherwise stated.
No dec pl : ± 0.5mm
1 dec pl : ± 0.2mm
2 dec pl : ± 0.1mm
3 dec pl : ± 0.05mm
angular : ± 0.2°
DO NOT SCALE



Drg By. MRN	Chk'd By.	Approved - date	Model Name prop driver	Date. 31/12/2011	Scale 2:1
Material. SEE ABOVE	Title. PARTS SHEET 3			Sheet number. A4 1 of 1	
Finish. Finish	Drg No. -				